

Saladette Mini-Saladette - 250lt, 2 Door with lid and chopping board (R290)

ITEM # _____

MODEL # _____

NAME # _____

SIS # _____

AIA # _____



110891 (ZSAL25L2C9)

2-door refrigerated Saladette
with lid and chopping board
250lt, +2+10°C, AISI 304

Short Form Specification

Item No.

Constructed entirely in 304 AISI stainless steel. High-density expanded polyurethane foam, 50 mm in thickness, with cyclopentane injection. Height-adjustable feet. Hinged lid on top. Lower refrigerated compartment designed to accommodate GN 1/1 containers and equipped with N. 2 hinged doors. Built-in refrigeration unit. Ventilated. Refrigerant R290. Digital control panel. Automatic evaporation of defrost water. Suitable to operate in ambient temperatures up to +43°C. Temperature range: +2+10°C. CFC and HCFC free.

Supplied with n.9 horizontal container supports and n.1 non-toxic plastic chopping board.

Main Features

- Forced air circulation for rapid cooling and an even temperature distribution.
- Automatic evaporation of defrost water. Prearrangement for drain outlet.
- Connectivity ready for real time access to connected appliances from remote and data monitoring (requires optional accessory).
- Digital control panel.
- Equipped with hinged lid for non-operating periods.
- Anti-tilt runners accept GN 1/1 containers.
- A kit of wheels is available as optional accessory for easier movement.
- Adjustable temperature range from 0°C to +10°C.

Construction

- IPX3 protected.
- Access to all components from the front.
- Built-in compressor to suit operating conditions.
- Constructed from AISI 304 Stainless steel throughout to meet the highest hygiene standards.
- Developed and produced in ISO 9001 and ISO 14001 certified factory.
- Mounted on legs with height adjustment.
- Rounded internal corners for ease of cleaning.
- Adjustable feet 66-88 mm (see optional accessory).

Sustainability

- CFC and HCFC free, highly ecological refrigerant type: R290 (ecological gas in foam: cyclopentane). Hydrocarbon refrigerant gas R290 for the lowest environmental impact (GWP=3), to reduce green house and ozone depletion effects.
- 50 mm insulation for energy saving.

Optional Accessories

- Kit 4 wheels for 250 lt counter/ saladette PNC 880267
- Feet to reach 900mm height for 250lt saladette PNC 881254
- 1/1 GN grey "rilsan" grid PNC 881435

APPROVAL: _____

Front

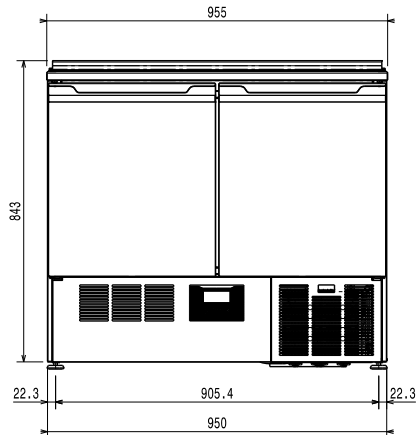

Side

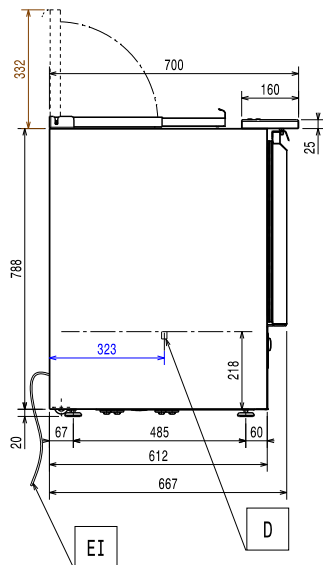

EI = Electrical inlet (power)

Top

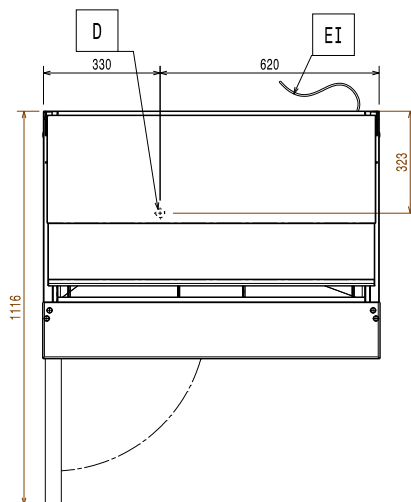

Electric

Supply voltage:

110891 (ZSAL25L2C9) 220-240 V/1 ph/50 Hz

Key Information:

Gross capacity: 250 lt
 Net Volume: 140 lt
 Door hinges: 1 Left+1 Right
Built-in Compressor and Refrigeration Unit
 External dimensions, Width: 950 mm
 External dimensions, Depth: 700 mm
 External dimensions, Height: 863 mm
 Depth with doors open: 1120 mm

Refrigeration Data

Compressor power: 1/4 hp

Sustainability

Refrigerant type: R290
 Refrigeration power: 314 W
 Refrigerant weight: 50 g